

# Who has the power in the EU?\*

Jason Barr<sup>†</sup> and Francesco Passarelli<sup>‡</sup>

January 2006

(updated from January 2004)

**Rutgers University Newark Working Paper #2004-005**

## Abstract

The European Union (EU) is facing the challenge of enlargement to almost double its previous size; this has important implications for the balance of power among member states. Building on the work of Shapley (1977) and Owen (1972), we present a measure of power that is based on players' preferences and number of votes. We apply this measure to the Council of Ministers to see who wields power now and who is likely to wield power in the future. We also provide a rationale to explain why the negotiations for the new Constitution have been so difficult. Further, we show how a country's power can change based on the preferences of the agenda setter, which, in this case, is the European Commission.

**JEL Classification:** C71, D72, D78, H11

*Keywords:* Power Indices, European Union, Principal Components

---

\*The authors would like to thank Massimo Bordignon, Sandro Brusco, Mario Gilli, Manfred Holler, Annamaria Lusardi and Stefan Napel for their comments and suggestions on earlier drafts. Finally we appreciate the helpful discussions with Alberto Alesina, Pierpaolo Battigalli, Gérard Roland and Guido Tabellini. Any errors are the sole responsibility of the authors.

<sup>†</sup>Rutgers University, Newark. Dept. of Economics, Newark, NJ 07102. email: jmbarr@andromeda.rutgers.edu.

<sup>‡</sup>Corresponding Author. University of Teramo and Bocconi University. email: francesco.passarelli@unibocconi.it

# 1 Introduction

The European Union (EU) is facing the challenge of an enlargement that has almost doubled the number of members. As of May 1, 2004, ten new members have entered the Union; two potential member states are taking steps towards full political and economic integration. The widespread beliefs are that the current institutional design is inadequate to face this challenge, and that the EU can no longer delay reforms that will give European decision-making mechanisms deeper democratic foundations and greater efficiency.

At the heart of the debate is the problem of locating the optimal balance between the intergovernmental nature of the Union, which is basically an agreement among sovereign member states, and the federal development of the EU. The attempt made by the Treaty of Nice (December 2000) to solve this historical dichotomy, and, at the same time, to prepare the Union for the enlargement has failed primarily because the representatives of the national governments were reluctant to change the current institutional architecture that grants more power to the member states (through the Council of Ministers) than to the European Parliament (directly elected by the citizens) and to the European Commission (a centralized institution with power of initiative).

In March 2002, a Constitutional Convention began working on the enormous undertaking of constructing a decision-making system that remains efficient and meets the principles of legitimacy and acceptability. After the intergovernmental negotiations and adjustments, the Convention's proposals were endorsed by the Bruxelles Summit on June 2004. In October, the heads of each the states signed in Rome the Constitutional Treaty (CT). However, the ratification process was stopped in June 2005 by two "no" votes in the French and Dutch referenda. As of December 2005, the member states are having a "reflection phase". If the new institutional rules come into force, there will be a new President for the European Council, a Vice-President in charge of foreign affairs, a new Commission, a more powerful EU Parliament, and *new voting schemes* for the Council of Ministers. The final outcome of the constitutional process is highly uncertain and the basic question is "what to save of the new Constitution?"

The issue of decision making within the Council itself is quite important. There is a broad consensus that even after the CT the Council will continue to have a prevailing role over the EU Parliament. The codecision procedure (i.e., the Parliament codesides issues with the Council) does not extend over

all the policy issues, and in areas such as foreign policy and internal affairs the Parliament plays a minor role. In addition, Napel and Widgrén (2004) using a Nash bargaining rationale, show that a qualified majority in the Council versus a simple majority in the Parliament gives the former more power than the latter, despite codecision.<sup>1</sup>

During the negotiations on the new constitution the weights reapportionment in the Council became one of the most important issues. Arguably, the countries have been evaluating the losses and the gains from the new system. Initially, Spain and Poland have opposed the proposed changes, saying that it will radically modify the power distribution among the member states. Only after some adjustments to the majority thresholds, did they accept the new CT. The new voting scheme, which, if ratified, will come into effect in 2009, and will change the current rules of the bargaining among the national governments themselves, the different levels of government (within the countries and between EU and country members) and the EU institutions. In this paper we focus on the game among the governments that takes place within the Council of Ministers.

## 1.1 Constitutional rules and European bargaining

Despite the relative narrowness of its budget, the EU has already acquired a wide set of competencies. The benefit from participating in the Union comes from the coordination and centralization of several policy areas, such as a single currency, internal and external trade, competition, international relations, and social protection. The literature on political economy, from fiscal federalism to contract theory, offers contributions on what the European Union should do and how it should be done (Alesina, *et al.*, 2002, Alesina and Perotti, 2004, Berglof, *et al.*, 2003).

The *distribution* of the EU *benefits* through negotiations and lobbying are part of the daily life of the EU institutions. Part of this bargaining game takes place at intergovernmental level: every Council meeting, including the preparatory work, can be considered a non-cooperative game played by the delegations of the states within the rules of the Treaty.

However, in the *constitutional phase* of writing the Treaty, it is important to abstract away from the political interests present in particular voting en-

---

<sup>1</sup>Noury and Roland (2002) show that the coalitions within the European Parliament follow “party group” dynamics, rather than “national” ones.

vironments and concentrate on the *rules* of the game, and on their ability to generate equitable opportunities to influence political decisions. As such, this analysis can be conducted within the theoretical framework of cooperative game theory. Thanks to the seminal work of Shapley and Shubik (1954), the concept of the *Shapley Value* (Shapley, 1953) is taken as an index of the *a priori* power of the members in a committee. In summary, the Shapley-Shubik index is a measure of the relative frequency with which a member country can determine the outcome of a particular vote if all possible coalitions of a fixed number of member states were equally likely to occur; and it is, in general, some function of the number of votes and the majority threshold.<sup>2</sup>

Conventional wisdom holds that France and Germany, for example, are the big “players” in the EU arena. This is simply true from an *a priori* consideration due to their having the largest number of votes and consequently the largest Shapley-Shubik indices. But why is the same power not conventionally assigned to Italy and United Kingdom, who have the same weight in the Council? Moreover, and in general, how are the preferences of the countries likely to affect outcomes? What will happen now that enlargement has taken place? Here, we expand upon the definition and measurement of power proposed by Shapley and Shubik. We discuss and estimate a spatial measure of the Shapley Value, which comes directly from the preferences of the member states. Our approach is able to address these questions.

This paper is novel in several respects. First, from a theoretical point of view, we present a simple analytic extension of the work of Owen and Shapley (1989). By directly incorporating the preferences of the players we generate a probabilistic-based power index. We argue that when the preferences of the players are stable and predictable, the “asymmetric” spatial perspective better captures the effects of long-lasting voting schemes agreed upon in constitutions. Second, we extend this theory in a new direction by

---

<sup>2</sup>In our analysis, the Shapley-Shubik index (and Normalized Banhalf Index) is a simple linear function of the number of votes of the nations. For example, for the 15 EU countries (pre-enlargement), with votes distributed according to the ‘Pre-Nice’ scenario, we can predict the Shapley Value from the votes by the simple OLS regression function:

$$\hat{SS} = -0.002 + 0.012 \text{Votes.}$$

(0.0009) (0.0014)

$R^2 = .998$ ,  $n = 15$ . Standard Errors below estimates.

modelling the effect that an *agenda-setter* can have on the outcome of the game. The interaction of the preferences of the players (e.g., the EU member countries) and the preferences of the issue-setter (e.g., the EU Commission) can substantially alter the power distribution among players. To the best of our knowledge, this approach has not been done elsewhere.

From an empirical point of view this paper is new in the following ways. First we directly measure the “political preferences” of the older and newer EU countries themselves. By analyzing EU-based polling data, we can get a measure of the extent to which member countries are relatively “pro” or “con” in regard to relinquishing decision making to the EU Council. We then apply these measured preferences to computing power indices for the EU countries. Finally, we measure how the distribution of power depends upon the preferences of the agenda setter.

By directly using these preferences we find some interesting and novel results:

- When considering the political positions of the countries, the number of votes is not necessarily a good predictor of power. For example, decreasing the qualified majority threshold (from the current scheme to the CT) tends to shift the power to countries with moderate preferences. The Franco-German axis emerges from the centrality of their preferences and their size. Little power rests upon the Northern “Euro-skeptics” or the Mediterranean “Euroenthusiasts.”
- The Euro-skeptics, such as the United Kingdom or Denmark, become prominent if unanimous decisions, like the EU budget or taxation, have to be taken.
- Under the system agreed at Nice, after the enlargement the older leaders tend to lose most. Having a certain degree of Euroenthusiasm will put Spain, for example, in a favorable position. Euroenthusiasm will in turn favor the newcomers. If the new Constitution does not come into force, the Eastern countries are likely to exercise a very strong political influence on the Council.
- In comparing the Nice arrangement to the new Constitution, the Nice rules will allow the Eastern countries to collect almost 40% of total power, despite less than one fourth of population. The reapportionment proposed by the CT favors moderate positions and restores the power

of the populous members, such as Germany and France. Spain emerges as a big player. The power shifts back to the Western members.

- A distorted pro-Europe Commission can cause the power to shift to countries located on the Euroskeptic side of the political space. This shift tends to be more important when voters have less vague expectations about the agenda setter’s preferences, when countries are highly dispersed on the political space, and when the majority threshold increases. The largest amount of power redistribution due to the agenda setter distortion occurs in the post-enlargement scenario with the Nice rules. The reallocation of power in favor of the large old members due to the CT scenario is partially offset when the Commission is pro-EU.

## 1.2 Literature review

Although “power” in political science is a “penumbral” concept (Shapley, 1977, p. 5), cooperative game theory has proved useful when investigating the influence that a voting system gives to the voters. Applications to national and international legislative bodies have gained legal importance in evaluating reapportionments of votes. The literature on applications of power indices to the European Council of Ministers is rich and widespread.<sup>3</sup> This is partially due to the frequent enlargements of the EU, which provide new voting distributions to evaluate. This literature consists in computing or refining the standard Shapley-Shubik (1954) or Banzhaf (1965) indices for the EU members; thus, one usual assumption is that the countries cannot be distinguished by their attitudes toward the EU. However, ignoring the “policy positions” of the European governments could yield an overestimation of the power of the national governments with extreme preferences. Moreover, *a priori* power indices cannot take into account the “location” of the EU Commission, which plays the role of agenda-setter for the Council.

---

<sup>3</sup>A very good survey on power indices is in Straffin (1994). General criticism of the implicit behavioral assumptions behind power index analysis is in Coleman (1971).

Holler and Owen (2001) and Felsenthal and Machover (1998) contain very good surveys and detailed references to the applications to the EU. On the application of this literature to other institutional contexts, see the survey by Benoit and Kornhauser (2002).

A general debate on power indices with some focus on the EU is in *Power Indices and the European Union*, a special issue of the *Journal of Theoretical Politics*, July 1999, Volume 11, No. 3.

The theory of spatial indices can provide a strong analytical background when ideological differences among players are crucial. Owen (1972) suggests a scheme of coalition formation that considers the ideological distance between voters in a political space. Building on Owen’s intuition, Shapley (1977) and Owen and Shapley (1989) provide a “non-symmetric” generalization of the Shapley-Shubik index in which each player’s power depends, in addition to the voting rules, on her location in a political space. This generalized spatial index emphasizes the role of ideology in coalition formation. In this scheme the coalitions are inspired by policy issues. Given a policy issue, the players can be ordered by the level of support for that issue. The support defines the ordering within a coalition; only the “ideologically consistent” orderings are considered. Thus the probability of a coalition emerging is related to the number of policy issues it is inspired from.

Owen and Shapley consider all the policy issues as equiprobable, assuming the absence of any information about the issue generating mechanisms. We argue that in the presence of an agenda setter some policy issues can be more likely than others. As a consequence, *ceteris paribus*, the countries which tend to be in pivotal positions in policy areas preferred by the agenda setter will have more power. In other words, the agenda setter alters the probability of the issues and distorts the distribution of the power.

In this context, the theoretical framework offers an interesting perspective for analyzing the political games that take place among the states’ representatives within the Council of Ministers of the European Union. It accommodates the most relevant criticisms raised about the application of power indices to the Council. The problem then becomes how to define a political space for EU matters and how to place countries in it. As far as we know, no empirical literature in regards to the EU tries to answer this question. Here we use principal component analysis (PCA) to extract the preferences of the countries toward the EU (in the spirit of Rabinowitz and MacDonald (1986), who use PCA for the U.S. presidential elections).

### **1.2.1 Cooperative versus non-cooperative political games**

The cooperative spatial approach for solving political games is not without controversy, and here we offer some comments and caveats. A non-cooperative view is frequently more suitable than the cooperative approach to illustrate contingent contexts of policy decision making, despite that strategic or extensive form games can have practical difficulties with complex insti-

tutional environments and intransitivity of majorities.<sup>4</sup> Cooperative games have the advantage of simplicity. However the nature of the coalitional agreements can be very complex and issues such as enforcement, representation, procedures, etc. can emerge.<sup>5</sup> Moreover the cooperative solution concepts often rely on hypotheses about coalition formation and bargaining that could appear too strong.<sup>6</sup>

These difficulties arise mostly when cooperative games are used to describe specific political situations, where the contingent aspects of the game and the strategic attitudes of the players are known and predictable. But these problems are less severe in a *constitutional perspective*, in which the analysis concerns a voting mechanism that will be applied to a large set of policy decisions and to a variety of different contingencies. In this perspective, attention can be restricted to a game in which the primary aim of the player is "... to succeed in forming certain decisive coalitions.... and there are no other motives which require a quantitative description." (Von Neumann and Morgenstern, 1944, p.424) Though this quote was discussing *simple* games, it fits perfectly for the constitutional perspective of a voting system in which we abstract away from contingent information.

Shapley (1953) offers a solution for symmetric games in which the coalition formation can be described as a random process. The Shapley solution is based on the *symmetry* of players, that is a situation in which the players "...do not offer to any player any possibility which is not equally open to any other player." (Von Neumann and Morgenstern, 1944, p. 224) In this perspective, any ordering of players is equally likely. The Shapley-Shubik index is the Shapley value for simple voting games. The ideological perspec-

---

<sup>4</sup>See Pearsson and Tabellini (2000) for a complete survey of models of political economy. An essential reference for the public choice theory is Mueller (2003).

<sup>5</sup>Snyder *et al.* (2005) compare the standard power indices with the equilibrium of a non-cooperative game *à la* Baron-Ferejohn with weighted votes. They find that the indices are not good predictors of the expected payoffs of the players.

<sup>6</sup>Sloss (1973) shows the relationships between the core and the existence of a Condorcet winner: games with an empty core present the Arrowian problem of cyclical majorities. In general, the core is empty for constant-sum games and it is very likely to be empty for spatial coalitional games with many players and a limited number of dimensions. The core is the most intuitive solution concept of cooperative games. However, even if it is empty, other solutions can reasonably be adopted, such as V-sets, kernels, bargaining sets and symmetric values.

See Owen (1995) for a survey of cooperative solution concepts. A complete reference on the difficulties of the cooperative spatial approach is Ordeshook (1997).



tive removes the symmetry assumption, allowing for orderings that are not equally likely. When players have a range of preferences for participating in different coalitions then the solution must be asymmetric.

Therefore, the ideological power analysis cannot explain how some specific decisions are made and implemented and how much value will be produced by a single decision. Moreover, using the ideological power index as a fair division of the “one dollar,” is questionable because, in general, if the game is not symmetric the Shapley solution is not unique. This is particularly true if side payments among players are not possible.<sup>7</sup> Summing up, when the players do not have identical attitudes, the ideological power analysis offers, at least, a measure of how likely each player is to be in a favorable position to influence on her own advantage the future majority decisions. This perspective can provide useful evaluations of the “players’ prospects” of having to play with different voting schemes.

The rest of the paper is organized as follows. Section 2 discusses the theoretical measures of power. Then in section 3 we present the results of our empirical analysis of the EU countries’ preferences and power measures. Next in section 4 we show how changing the agenda-setter preferences affects the distribution of power. Section 5 concludes. Several appendices contain technical information for the interested reader.

## 2 The theory of voting power

Consider a set  $N = \{1, 2, \dots, n\}$  of players and denote by  $2^N$  the collection of subsets (*coalitions*) of  $N$ . A game is a real-valued function  $v : 2^N \rightarrow \Re$  that measures the worth of each coalition. Let  $\mathcal{G}$  be the collection of all games on  $N$ . For a given player  $i$ , let  $p_T^i : T_i \subseteq N \setminus i$  be a *probability distribution* over the collection of coalitions not containing  $i$ , with  $\sum_{T_i \subseteq N \setminus i} p_T^i = 1$  for all  $i$ .

**Definition 1** *A value  $\phi_i$  for  $i$  on any collection of games  $\mathcal{T} \subset \mathcal{G}$  is a probabilistic value if for every  $v \in \mathcal{T}$  :*

$$\phi_i(v) = \sum_{T_i \subseteq N \setminus i} p_T^i [v(T_i \cup i) - v(T_i)] \quad (1)$$

---

<sup>7</sup>For surveys on asymmetric Shapley solutions and on values for non-transferable utility games, see Monderer and Samet (2002) and McLean (2002), respectively.

$E(T_i) \equiv p_T^i \cdot [v(T_i \cup i) - v(T_i)]$  is player  $i$ 's expected worth from joining the coalition  $T_i$ . From a probabilistic viewpoint, the value of the game for player  $i$  is a measure of her prospects from playing the game; it is calculated by summing up the expected values of participating in all the possible coalitions.

If  $v$  takes only the values 0 and 1, the game is said to be “simple” and if  $v(S) = 1$  (with  $S \subseteq N$ ), then  $S$  is a *winning* coalition, otherwise  $S$  is a *losing* one. For a given simple game  $v$  and a coalition  $T_i \subseteq N \setminus i$ , the player  $i$  is called the *pivot* if  $v(T_i) = 0$  and  $v(T_i \cup i) = 1$ .

In other words, being in the pivotal position allows player  $i$  to change the worth of the coalition. Arguably, in political situations, casting the vote that turns one coalition from losing to winning is a valuable position, worthy to be rewarded by the other voters already in the coalition. This gives rise to the question: How much do the voting rules influence each player's relative frequency to cast the swing vote?

The pivot is the member who casts the “last” vote needed for the passage of a bill. The ordering of the support to the bill is then relevant, but in Shapley-Shubik's perspective it is taken at the most abstract level since no information about the members' preferences are available, and only the rules of the game are relevant. Thus, if we interchange the players, the value of the game for an individual in a particular position will be the same as the one assessed by any other player in that position. This is the basic idea of the symmetric approach which inspires the Shapley-Shubik index.<sup>8</sup>

---

<sup>8</sup>“Abstract games are played by *roles* ... rather than by *players* external to the game” (Shapley, 1953, p. 308). Thus the individuals cannot be distinguished by their level of enthusiasm or lack thereof when they participate in a certain election, and the bills cannot be characterized by a measure of their “acceptability” (see “Axiom 1” in Shapley (1953), p. 309).

In a political game, this justifies the *abstract* idea of voters, who subjectively believe that all the coalitions are equally likely to be of any size and that all the coalitions  $T_i \subseteq N \setminus i$  of size  $t$  (with  $t = |T_i|$ ) are equally likely. In sum, for any player  $i$ , we get the Shapley Shubik index if we substitute the following in (1),

$$p_T^i = \frac{1}{n} \binom{n-1}{t}^{-1}$$

(Weber, 1988. p. 103).

Retaining symmetry, we get another famous measure of power due to Banzhaf (1965) when the players believe that each coalition  $T_i \subseteq N \setminus i$  has equal probability

$$p_T^i = \frac{1}{2^{n-1}}.$$

## 2.1 Preferences and power

Symmetry is a desirable assumption if we do not have information about the attitudes and differences among the players. In many situations, however, we have knowledge about the preferences of the players and we can use it to evaluate the most likely outcomes of the game. Ultimately, the value of the game for any player and the solution of the bargaining problem should depend on the personal characteristics of each participant, as far as we have information about those characteristics.

This is particularly true in political games when the voters can be assumed to vote according to their political profiles over an  $m$ -dimensional political space. In the simplest case of one dimension, for example, we can think of congressmen being distributed on a left-right wing axis. We can add political dimensions if we detail the political preferences (e.g., pro/con federalization of political areas, pro/con strict budget policies, etc.).

We expect that ideologically similar players will tend to behave similarly in coalition formation. This means that coalitions with ideologically similar players are more likely to emerge than coalitions that have distant voters. In a probabilistic perspective, we should relate the ideological positions of the players to the randomization scheme that assigns a probability to each coalition in  $2^N$ .

Suppose each voter  $i$  has an ideal point (or location)  $P_i \in \mathfrak{R}^m$  in an  $m$ -dimensional Euclidean space, where each dimension captures the ideological parameters of the (political) game. Let  $\Psi \subseteq \mathfrak{R}^m$  be the set of all the issues to vote on. Each issue is a vector  $U \in \Psi$ .

Suppose we have a function  $f_i(U)$  such that  $f_i : \Psi \rightarrow \mathfrak{R}$  exists for each player  $i = 1, \dots, n$  and measures player's  $i$  level of enthusiasm toward the issue  $U$ . Thus, we can induce an ordering  $\prec$  on  $N$  through the  $f_i(U)$ 's. More precisely,

$$j \prec i \text{ iff } f_j(U) - f_i(U) \geq 0. \quad (2)$$

Equation (2) says that if player  $j$  is more enthusiastic than player  $i$  when the issue  $U$  is proposed, she will vote “yes” before player  $i$ .

Let  $U$  be randomly chosen from a probability distribution  $p(U) : \Psi \rightarrow [0, 1]$ . Since  $U$  is a random vector, we can define the random variable  $Y_{ij} = f_i(U) - f_j(U)$ . Note that if  $Y_{ij} \leq 0$  player  $j$  will participate before  $i$ .

---

It is clear that both the Shapley-Shubik and the Banzhaf indices can be helpful methods to determine the distribution of the power if the “names” of the players do not matter.

Consider the coalition  $T_i \subseteq N \setminus i$  and let  $A_U^{T_i}$  denote the subset of  $\Psi$  such that  $j \in T_i$  iff  $Y_{ij} \leq 0$ . Then the probability of observing  $T_i$  is given by

$$p_T^i = \int \cdots \int_{A_U^{T_i}} p(U) dU. \quad (3)$$

Equation (3) says that the probability of a coalition in which some players  $j$  enter before  $i$  is given by the probability of observing all the issues  $U$  for which players  $j$  are more enthusiastic than  $i$ .

In particular, via (3) we define a probability distribution over the set of the possible coalitions not containing  $i$ ,  $p_T^i : 2^{N \setminus i} \rightarrow [0, 1]$ . This is useful to characterize a probabilistic value in a spatial context.

**Definition 2** *A value  $\phi_i$  for  $i$  on any collection of games  $\mathcal{T} \subset \mathcal{G}$  is a probabilistic spatial value if for every  $v \in \mathcal{T}$ ,  $\phi_i$  is defined by (1) and  $p_T^i$  is defined by (3).*

For a given simple game  $v$ , player  $i$ 's value  $\phi_i(v)$ , specified by (1) and (3), can be interpreted as the probability of being in a pivotal position, out of all the possible coalitions that the random issue  $U$  can inspire. Of course, since the pivotal argument is useful for evaluating the voting rules from an a priori perspective, we require that the locations capture long run policy attitudes of the voters.<sup>9</sup>

### 2.1.1 The Owen-Shapley scheme

Owen and Shapley (1989) propose to restrict  $U$  to lie on the unit-sphere  $H_{m-1}$ . This is equivalent to imposing

$$\langle U, U \rangle = 1 \quad (4)$$

---

<sup>9</sup>As pointed out above, our analysis is at the constitutional level. The use of this approach to describe *specific* voting contexts is questionable, since additional information about the policy outcome would need to be embodied in the characteristic function. Moreover *that* specific outcome should correspond to a point in the policy space, and more detailed information about the preferences of the players with respect to that specific point should be included. Finally, assumptions about the transferability of utility or the ability of the voting game to generate efficient outcomes should also be made.

for all  $U \in \Psi$ . Moreover they introduce a special formulation for the  $f_i$ 's, whose nice characteristics will become clear soon:

$$f_i(U) = \langle U, P_i \rangle \quad (5)$$

Finally, Owen and Shapley assume that  $U$  is chosen from  $H_{m-1}$  by a uniform probability distribution and that  $v$  is a simple game, then they conclude that  $p_T^i$  is the Lebesgue-measure of what we have called  $A_U^{T_i} \subset H_{m-1}$ .

Combining the (4) and (5) into the spatial context depicted above we get a probabilistic characterization of the Owen-Shapley spatial value. In section 2.2 below we provide an example of a game with three players in a two dimensional political space.

Now we will show that the probabilistic value defined by Owen-Shapley's randomization mechanism may represent an equitable distribution scheme of the full yield of the game; in other words, the vector  $\phi(v) = (\phi_1(v), \dots, \phi_n(v))$  can represent the payoffs of the players from participating in the game  $v$ . We know that this corresponds to satisfying the so called *efficiency axiom* (see Axiom 2, Shapley(1953, p. 309)); i.e. if for every  $v \in \mathcal{T}$ ,  $\sum_{i \in N} \phi_i(v) = v(N)$ .

Weber (1988, p. 113) demonstrates that a probabilistic group value  $\phi = (\phi_1, \dots, \phi_n)$  on a collection  $\mathcal{T}$  of asymmetric games satisfies the efficiency axiom iff: (a)  $\sum_{i \in N} p_{N \setminus i}^i = 1$  and (b)  $\sum_{i \in T} p_{T \setminus i}^i = \sum_{t \notin T} p_T^t$  for every nonempty  $T \subseteq N$ .<sup>10</sup>

**Proposition 1:** *The probabilistic spatial value defined by (1), (3) and by (5) satisfies the efficiency axiom.*

**Proof.** We have to show that both (a) and (b) are satisfied.

- (a) Consider that from (3)  $p_{N \setminus i}^i = \int \dots \int_{A_U^{N_i}} p(U) dU$ . Remember that for

any  $i \in N$ ,  $A_U^{N_i}$  is the subset of  $H_{m-1}$  in which  $i$  comes last. It easy to see that  $\bigcap_{i \in N} A_U^{N_i}$  has zero Lebesgue-measure, and  $\bigcup_{i \in N} A_U^{N_i} = H_{m-1}$ ,

$$\text{then } \Pr \left\{ \bigcup_{i \in N} A_U^{N_i} \right\} = \sum_{i \in N} p_{N \setminus i}^i = 1.$$

---

<sup>10</sup>Probabilistic values that satisfy the efficiency axiom are called *quasivalues* and can be done a *random-order* description. An essential reference on quasivalues is Monderer and Samet (2002).

- (b) Let  $T_i$  be any possible subset in  $N \setminus i$ . From the randomization scheme  $\sum_{i \in T} p_{T \setminus i}^i = \int \cdots \int_{\bigcup_{i \in T} A_U^{T_i}} p(U) dU$  and  $\sum_{t \notin T} p_T^t = \int \cdots \int_{\bigcup_{t \notin T} A_U^T} p(U) dU$ . Thus,

in order to satisfy the (b) we must have (b.1):  $\bigcup_{i \in T} A_U^{T_i} = \bigcup_{t \notin T} A_U^T$  for every nonempty  $T \subseteq N$ . The left hand of (b.1) is the set of all the  $U \in H_{m-1}$  such that for all  $j \in T_i$  and all  $t \notin T_i$ ,  $Y_{ij} \leq 0$  and  $Y_{it} \geq 0$ . For every  $T$ , call  $i$  the “least enthusiastic” player. Thus the right hand of (b.1) is the set of all the  $U \in H_{m-1}$  such that for every player  $t \notin T$  and every  $j \in T$  we must have  $Y_{it} \geq 0$  and  $Y_{ij} \leq 0$ . It is easy to see that the two unions coincide for every  $T \subseteq N$ .

■

## 2.2 An example

As an example, in figure 1 we present graphically a 2-dimensional political space with 3 voters,  $N = \{a, b, c\}$ , who have ideal points  $P_a, P_b$  and  $P_c$ . Below we consider a simple political game and compute the probabilistic spatial power index, adopting the Owen-Shapley ordering generating mechanism.

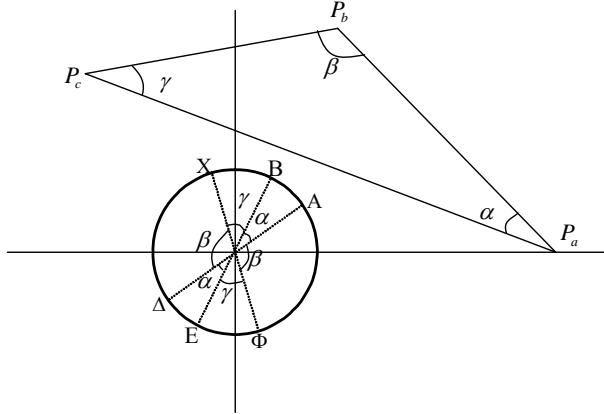

Figure 1: An example of a spatial game in two dimensions.

For two dimensions,  $H_{m-1}$  is the unit circle  $H_1$ , and the random vector  $U$  can be any point on  $H_1$ . Due to this, every  $U \in H_1$  can be identified by

one and only one angle,  $\theta \in [0, 2\pi)$ , by the function  $U = (\cos \theta, \sin \theta)$ . Exploiting this bi-univocal correspondence  $U \leftrightarrow \theta$ , we can conveniently reduce the number of dimensions by one. Hereafter, for two dimensional cases, we will refer to the value of  $\theta$  as the political issue.

In figure 2 we have drawn the ordering functions  $f_i(\theta) : [0, 2\pi) \rightarrow \mathfrak{R}$  for all the players  $i \in N$ . Given the player  $i$ 's political profile,  $f_i(\theta)$  measures her level of enthusiasm in supporting the bill "inspired" by the political issue  $\theta$ . We can see that, for example, as long as the proposed bill lies within the interval  $[0, A)$  voter  $a$  will say "yes" first; player  $b$  will come after, and  $c$  will be the last one. In other words, the coalition  $T_a$  of players more enthusiastic than  $a$  is empty if the political issue is within  $[0, A)$ . Below we report all the possible coalitions  $T_a$  of players more enthusiastic than  $a$  and the subsets of rotation of  $U$  over  $H_1$  (or, equivalently, the movement of  $\theta$  along  $[0, 2\pi)$ ) that generate those coalitions.

$$\left\{ \begin{array}{l} T_a = \{\emptyset\} \\ T_a = \{b\} \\ T_a = \{c\} \\ T_a = \{b, c\} \end{array} \right\} \text{ takes place if } \left\{ \begin{array}{l} \theta \in [0, A) \cup (E, 2\pi) \\ \theta \in [A, B) \\ \theta \in (\Delta, E] \\ \theta \in [B, \Delta] \end{array} \right\}$$

In figure 2 all the possible  $n!$  orderings are listed in the row at the top of the graph. Note the correspondence between the width of the angles  $\alpha$ ,  $\beta$  and  $\gamma$  in figure 1 and the subsets of  $[0, 2\pi)$  on the horizontal axis of figure 2.

Within this political space let's now consider the game  $v_1 = [3; 2, 1, 1]$  in which the qualified majority threshold is three votes out of four; player  $a$  can cast 2 votes,  $b$  and  $c$  each have 1 vote. What is player  $a$ 's prospect from playing this game? It's easy to see that player  $a$  succeeds in being pivotal only if at least one player has said "yes" before her. Thus her power in this game is given by the probability of observing any  $T_a \subseteq \{N \setminus a\} \setminus \{\emptyset\}$ . This probability is the player  $a$ 's power index for the game  $v_1$ .

Let  $p(U)$  be the probability distribution of the random vector  $U$  over the unit circle. Considered that  $U = (\cos \theta, \sin \theta)$  is a one-to-one transformation from  $H_1$  to  $[0, 2\pi)$  we can specify the density function  $p(\theta)$  for the random variable  $\theta$ . In particular,  $p(\theta) : [0, 2\pi) \rightarrow [0, 1]$  and  $\int_0^{2\pi} p(\theta) d\theta = 1$ .

Having specified  $p(\theta)$  and the ordering generating mechanism induced by  $f_i(\theta)$ , we can now compute the probability of any possible coalition  $T_a \subseteq N \setminus a$  by integrating  $p(\theta)$  over the subsets of  $[0, 2\pi)$  in which that coalition occurs.

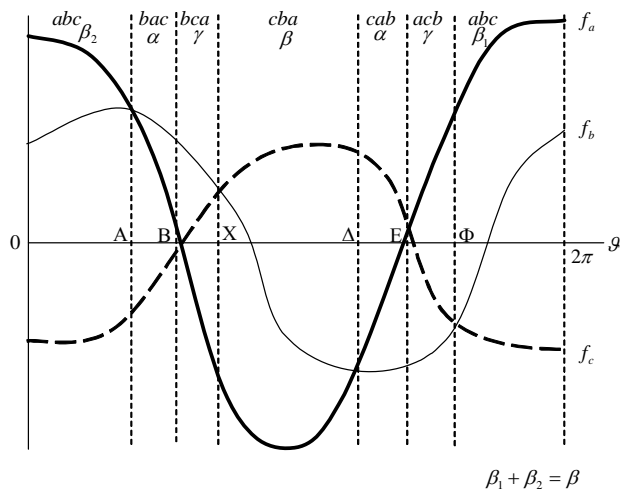

Figure 2: Orderings for three players from 0 to  $2\pi$ .

For example  $pr \{T_a = \{b, c\}\} = \int_B^{\Delta} p(\theta) d\theta$ .

Returning to player  $a$ , her chance of being a pivot is:

$$\phi_a(v_1) = \int_A^E p(\theta) d\theta$$

Owen and Shapley (1989) suppose that the political issues have equal probability of being on any point of the unit-circle. They justify this hypothesis by the absence of information about the circumstances that can affect the proposed bill. With uniform probability, it is easy to see that the power index for player  $i$  is given by the proportion of  $[0, 2\pi)$  in which coalitions for which  $i$  is pivotal are generated (the shaded area in the figure 3). In our example above, voter  $a$ 's power index would be,  $\phi_a(v_1) = (E - A)/2\pi$ .

The spatial value defined by (1), (3) and by (5) is related to a point  $X^*$  in the Euclidean political space that is dominated by a set of points with minimum Lebesgue measure. In other words,  $X^*$  is the policy outcome with the lowest probability to be beaten by any other alternative; i.e. it is a ‘‘Copeland winner.’’ This is a nice characteristic of the Owen-Shapley method, especially for games with and empty core, since it helps to predict where policy outcomes are likely to be located. Unfortunately this result has



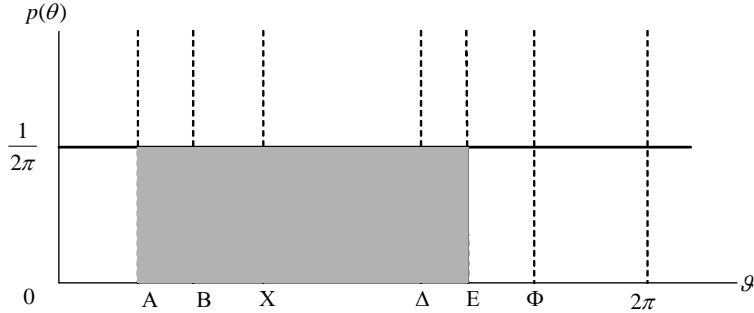

Figure 3: Power index with uniform probability distribution.

been proved only for simple majority games and for uniformly distributed issues (Grofman et al., 1987 and Owen and Shapley, 1989).

### 2.3 The political wind

In our spatial political games the random variable  $U$  captures the “blowing wind” that inspires the bill the voters are called to vote for. We can reasonably assume  $U$  as determined by random circumstances outside the control of the players. However, in some cases a certain amount of knowledge about the likelihood of these circumstances is available to the players and it can justify a non-homogeneous probability distribution over all the possible political issues that inspire a bill. Of course, we require that all the players share the same knowledge consistently.<sup>11</sup> If the issues that generate a certain coalition are highly likely, the subjective probability that the players assign to that coalition will be high as well. The probability of the issues will influence the player’s prospects from adopting a given voting system.

In figure 4 we have a radically different story from figure 3: the issues that inspire coalitions for which  $a$  is pivotal are relatively unlikely. This can change the players’ prospects substantially; the power of player  $a$  is very low, despite the veto power and the relatively favorable political position. In general, in spatial political games the power of the players will be determined, not only by the votes and the relative positions, but also by the probability

<sup>11</sup>Heuristically the conditions on which the efficiency of the power index depends (see also proposition 1 above) require that all voters share the same probability distribution over the set of all possible coalitions.

distribution of the issues, and ultimately by all the known circumstances that can influence the political content of the bills.

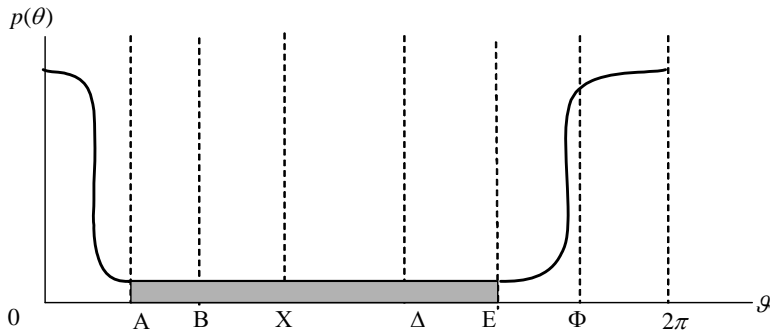

Figure 4: Power index with non-uniform probability distribution.

## 2.4 The agenda setter

The factors that can affect the political nature of the bill include the preferences of the institutions that have prerogatives in setting the policies to be voted on, the order in which policies are voted on, and the way the policies to vote on are split or grouped. Usually, however, the “agenda setter” (i.e., the institution that proposes new policies) does not directly vote in the committee. Despite this, its ability to affect the voting outcome is positively related to a series of variables, such as the degree of monopoly power in setting the agenda, the amount of information regarding voters’ preferences, and the scope of implementing complex voting sessions (sequential referenda, sophisticated voting, etc.). These topics have been deeply explored in the framework of non-cooperative game theory, starting from the pioneering work by Romer and Rosenthal (1978).

In this paper we look at the power of the agenda setter in a more abstract light, where bills are generated at random. If there is an agenda setter with a certain monopoly in proposing the bills, the probability distribution over the set of all possible bills will reflect the type of the agenda setter. The type includes any relevant information for the agenda setter’s decision making such as payoffs, institutional constraints, beliefs about the voters’ preferences, etc. We assume that the voters can infer the likelihood of each issue from a probability distribution over the set of all types.

Let  $\Upsilon \subseteq \mathfrak{R}^m$  denote the space of all the possible types of agenda setter  $T$ . We assume that the voters share common knowledge about the distribution  $q(T)$  over  $\Upsilon$ , from which the types are drawn. Let  $U = s(T)$  be the optimal issues the agenda setter proposes as a function of his type. We assume that  $s$  exists and that the voters have common knowledge of it. Thus the voters can use their beliefs,  $q(T)$ , to compute a distribution,  $p(U)$ , that illustrates how likely each issue is. We want to show that, under some general hypotheses, a higher probability assigned to a certain type implies a higher probability of the optimal bill being selected by that type.

Our investigation into the effect of the agenda setter in this paper is somewhat general. Here the agenda setter is described as the only institution that affects the direction of the blowing political wind. No specific analysis of his preferences or strategies is introduced, such as his ability to promote social rather private welfare or his independence from the players. More specific assumptions on the behavior and preferences of the agenda setter would be too specific in this stage of analysis, and potentially incompatible with our *a priori* approach. Nonetheless, one can view this game as if there was a non-cooperative pre-stage in which the agenda setter chooses his equilibrium pure strategy from  $\Psi$ . In the cooperative voting game presented below the voters anticipate how the agenda setter will play from the knowledge that they have of his type. Thus, we are keeping the characteristics of the pre-stage at the most general level.

**Proposition 2:** *If there exists a continuous joint distribution  $q(T)$ , over  $\Upsilon \subseteq \mathfrak{R}^m$  and a one-to-one function  $s : \Upsilon \rightarrow \Psi$  whose inverse is continuous, then there exists a probability distribution,  $p(U) : \Psi \rightarrow \mathfrak{R}$  and a one-to-one function  $h : \Upsilon \rightarrow \mathfrak{R}$  such that*

$$p(U) = q(T) \cdot h(T).$$

**Proof.** Since  $s : \Upsilon \rightarrow \Psi$  we can specify:

$$\begin{aligned} u_1 &= s_1(t_1, \dots, t_m) \\ &\dots \\ &\dots \\ u_m &= s_m(t_1, \dots, t_m), \end{aligned} \tag{6}$$

with  $U = (u_1, \dots, u_m)$  and  $T = (t_1, \dots, t_m)$ . Moreover, since  $s$  is a one-to-one transformation we can invert the  $m$  equations in (6) and we obtain:

$$\begin{aligned} t_1 &= g_1(u_1, \dots, u_m) \\ &\dots \\ &\dots \\ t_m &= g_m(u_1, \dots, u_m). \end{aligned} \tag{7}$$

Since the  $g_i$ 's are continuous, then for every  $i = 1, \dots, m$  and  $j = 1, \dots, m$  each partial derivative  $\partial g_i / \partial u_j$  exists at every point  $(u_1, \dots, u_m) \in \Psi$ . Thus the *Jacobian*,  $J$ , of the inverse transformation (7) can be constructed. Exploiting a common result of the probability theory, we know that

$$p(U) = \begin{cases} q(g_1, \dots, g_m) \cdot |J| & \text{for } U \in \Psi \\ 0 & \text{otherwise} \end{cases} \tag{8}$$

Proposition 2 is proved if we take  $J(T) = h(T)$ . ■

**Corollary 1:** *If  $q(T)$  increases (decreases) for some  $T$ , then  $p(s(T))$  increases (decreases).*

**Proof.** Just observe that  $|J|$  in (8) is always positive. Thus  $p$  and  $q$  are positively related. ■

**Corollary 2:** *For any subset  $A \subseteq \Psi$ ,*

$$\int_A \dots \int_A p(U) dU = \int_A \dots \int_A q(T) \cdot |J(T)| d(g_1, \dots, g_m) \tag{9}$$

**Proof.** This proof is trivial. ■

The meaning of the proposition and the corollaries above is simple and can be described by the following example. A Prime Minister (the agenda setter) is going to start his mandatory period. In order to anticipate the political content of the bills he will propose, the political groups in the Parliament (the voters) are likely to use their knowledge about, say, the electoral promises of the Prime Minister, his political profile, his linkages with interest groups, etc. Then if, for example, the Prime Minister is perceived to be strongly in favor of environmental protection, the groups will reasonably expect bills with high expenditures in this area. As a consequence, coalitions that include pro-environment groups will be perceived as more likely than coalitions that

exclude them. Moreover, the pro-environment parties will tend to vote “yes” before the others. As a result, each group’s view of being in a pivotal position will be anticipated accordingly. In other words, the voters’ perception about the agenda setter’s attitudes can distort the distribution of the power. Hence, a power index, even an *a priori* one, should not disregard any available information about the type of agenda setter.

### 3 The European political game

The EU has recently enlarged to 25 countries and in the next years further enlargements to 27 and possibly more members will occur. Thus, the number of the possible orderings of states is very high. Nevertheless, the question of which possible orderings are more likely should be deepened in order to shed light on possible political outcomes in the future EU. In our spatial analysis we expect, for example, that orderings in which Slovenia (rather Euroenthusiastic) and Denmark (usually Euroskeptical) occupy close positions will be rather unlikely; whereas, coalitions in which France and Germany are in close and “central” positions will tend to occur very often. One aim of our political analysis is to give structural valence to these subjective perceptions.

We use factor analysis (principal components) to identify the political preferences of the countries, and to provide their locations within the political space. We then use these preferences to measure power with the spatial pivotal approach. In this section we adopt the Owen-Shapley ordering generating mechanism based on  $f_i = \langle U, P_i \rangle$  and on a uniform probability distribution of the issues over  $H_{m-1}$ . We then compute the Owen-Shapley (spatial O-S) values and compare them with Shapley-Shubik (S-S) and normalized Banzhaf indices (NBI).

The data set that we employ to build up the political space comes from the Eurobarometer (EC, 2003). The Eurobarometer polls European citizens of their stance toward several policy issues, which range from domestic issues such as crime and poverty to international issues such as foreign policy and defense. We use three years of data that was collected for *all* 27 countries in the Fall of 2001, the Fall of 2002 and the Spring of 2003. Data reveal that the preferences of the citizens are rather stable over time.<sup>12</sup> This method of building the political space is based on the assumption that the way the Min-

---

<sup>12</sup>We have not used more recent surveys, since the Eurobarometer questionnaires after 2003 have slightly changed, making aggregation of data sets more problematic.

isters represent the preferences of the citizens is the same for each country and is not affected by differences in the national electoral systems. Moreover, we assume that there is no conflict of interest between citizens and representatives; we exclude any agency problem from our analysis at this stage.

We employ principal component analysis to reduce the number of variables to two latent factors that capture much of the variance in the data.<sup>13</sup> We compute the two main principal components for each year, then we calculate our Owen-Shapley spatial values and finally we take averages to make the results more robust. Though the preferences of the European countries are relatively stable over time, the O-S method is rather sensitive to the positions of the players in the political space; this is why we take averages over the three years to offset this undesirable characteristic of O-S. Appendix A contains the list of issues from the Eurobarometer. In Appendix B, we list the rotated factors for Spring 2003 to illustrate how the political space has been constructed. Information on the calculation of the Owen-Shapley spatial values is provided in Appendix C.

### 3.1 The political space

**The EU 15** Factor analysis captures well what is subjectively recognized about the attitudes of the countries toward EU policy issues. The first two principal components account for over 70% of the variation in the data. Thus we limit our analysis to the first two factors, benefiting also from the graphical representation of the two-dimensional political space. After applying (varimax) rotation and “scoring” the factors, a clear pattern emerges.

- The first factor – denoted as the “inter-national stance” – measures the degree to which each country would like to have a strong EU on the international scene (centralized foreign policy, common defence, common fight against international crime, harmonized rules in justice, environment, etc.).
- The second factor – denoted as the “intra-national stance” – represents the desired involvement of the EU in the “internal policies” of nations, which include areas in which the EU has already acquired strong responsibilities (agriculture, taxation, welfare, poverty, justice,

---

<sup>13</sup>See Lawley and Maxwell (1971) for more information on principal component analysis.

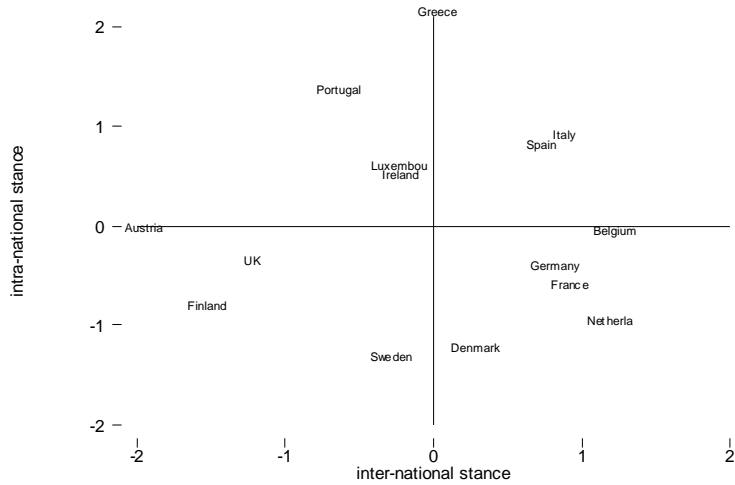

Figure 5: EU 15 stance toward EU (Spring 2003).

etc.). Member states with high intranational stance desire to relinquish more responsibility in those policy domains to the EU.<sup>14</sup>

Figure 5 represents the political space which originates from our factor analysis (using the Spring 2003 data). It includes the former 15 members before the 2004 enlargement. It shows, for example, the UK’s Euroscepticism and the Franco-German closeness. As well, we can see that the “oldest” members (Luxembourg, Netherland, Belgium, France, Germany, and Italy) are more favorable to further developments of the EU’s presence on the inter-national scene. The small and “older” members (Austria, Finland, Portugal) are less in favor of a stronger EU in foreign policy and have differentiated attitudes toward the EU involvement in domestic policy domains.

Each of the plotted factors has a mean of zero and a standard deviation of one; thus we can think of each country’s factor as the number of standard deviations away from the mean stance. For example, Finland’s score (for Spring 2003) for the inter-national stance is -1.6, which is 1.6 standard

---

<sup>14</sup>The names we give to the two latent factors should not be overemphasized. We have observed that the way each factor was related to the policy domains allows us to characterize the two dimension of the political space. The fact that the dimensions have a meaning is attractive, but not crucial for the power measurement. Details on this are provided in Appendix C.

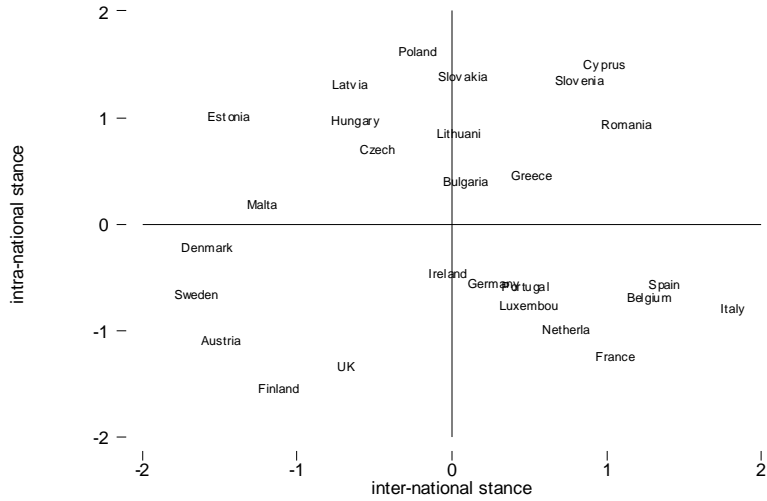

Figure 6: EU27 stance toward the EU (Spring 2003).

deviations away from the average stance.

Observe that for some of the 26 surveyed policy issues the member states decide with different procedures. For example, decisions on foreign policy, defence, and most of taxation or welfare require unanimity. In the factor analysis we do not treat these issues differently. We implicitly assume that the political space derives from a uniform view the citizens look at the European policy making. The way different citizens look at similar issues is highly correlated to their nationality. This justifies our assumption. Another note of caution is that, unfortunately, the Eurobarometer does not include questions on the single market.

**The EU 27** In regards to the 27 current and potential member countries, the first two principal components also account for roughly 70% of the variance in the data. We again found a similar pattern: that first factor is the stance toward the EU on inter-national issues, while the second factor is the stance toward the EU on domestic issues. The ideal points are presented in figure 6.

The newcomers from Eastern Europe tend to have generalized strong attitudes toward EU centralization in domestic policy domains (high intranational stance). A certain degree of diversity is associated to the inter-national



stance, probably due to mixed-feelings toward nationalism.

A rapid comparison of figures 5 and 6 reveals that the “topology” of the coalitions will change radically in the next few years, after enlargement. The “center” of the EU political space moves upwards, i.e., at least for intra-national issues, the average propensity to centralize the decision making at European level raises consistently. Some old members that could be considered relatively Euroenthusiasts become moderate, if not Euroskeptical after enlargement.<sup>15</sup> We expect that countries that were determinant (pivotal) for some policy issues and irrelevant for some others will probably be in a very different position after the new members will have joined. Below, we provide quantitative evidence of these changes.

## 3.2 Measures of power

As discussed above, our objective is to evaluate the relative frequency that each European member is pivotal within the Council of the Ministers, recognizing that the probabilities of the coalitions are constrained by the preferences of the players. We present three different voting games to highlight how the interaction of voting rules and preferences can alter the distribution of power.

1. The first is the pre-enlargement situation: 15 members and vote allocation more favorable to the small and middle-size countries. We will refer to this scenario as *pre-Nice*.

2. The second scenario takes into account the enlargement of the EU by the 12 potential members and the re-weighting agreed at Nice. This is what we call the *post-Nice* scenario. It has come into force as of November 1<sup>st</sup> 2004.<sup>16</sup>

---

<sup>15</sup>Observe that here we are talking about the *relative* attitudes of the countries toward the EU. The coordinates of the graphs change as a result of the factorial analysis. Intuitively, the origin of the graph somehow reflects the *barycentre* of the political space. The position changes after the enlargement do not imply that the citizens change their mind toward the EU because of the enlargement. It rather means that it is the centre of the space to have shifted after enlargement.

Since our analysis is intended to generate all the possible orderings of the players, then any possible issue of the political space (on  $H_{m-1}$ ) is considered. We do not have one specific point of the space that represents the *status quo*.

<sup>16</sup>Changes in votes allocation from pre-Nice situation to post-Nice can be seen by comparing column two of tables 1 and 2 below. In the Treaty of Nice the qualified majority threshold was increased from 62 out of 87 to 250 out of 345.

3. The third scenario is the *Constitutional Treaty* (CT): in which the old weighted voting system is substituted by a double majority based on both population and number of countries.<sup>17</sup>

**Pre-Nice – 15 Members** Table 1 shows the results for the Pre-Nice scenario. It reports the standard Shapley-Shubik index (S-S), the normalized Banzhaf index (NBI) and the spatial index in the Owen-Shapley perspective (O-S spatial). If we look at the O-S spatial values we see that the number of votes is no longer a good predictor of power. Shifting from standard S-S and NBI indices to the spatial value yields a concentration of power. This is due to zero-probability assigned to a large number of ideologically non-consistent coalitions.

Since the qualified majority threshold is roughly 70%, we expect that those countries who tend not to be “highly enthusiastic or completely reluctant” in participating coalitions on random political issues will have more chances to be pivotal. In other words, the most powerful are the ones who say “yes” neither “too early” nor “too late”; they cast their vote broadly after the other more enthusiastic countries have already cast almost the two-third of the votes, and before the more reluctant ones have cast theirs. For such countries the spatial O-S power index tends to be higher than the standard S-S or NBI indices. Conversely, the power measure decreases for countries who have extreme preferences (very strong or very little enthusiasm for Europe).

Austria, Belgium, Spain, Germany and Portugal gain substantial power from occupying favorable positions in the ideological space.<sup>18</sup> The traditional view of a strong Central Europe led by the Franco-German axis and

---

The Treaty of Nice prescribes also that bills are passed by the Council with two quotas: a majority of states, *and* at least 62% of the total population of the Union. These additional conditions produce negligible effects on winning coalitions. Then, we disregard in our analysis these and other complex aspects of the EU decision making, such as amendments, abstentions, etc.

<sup>17</sup>The double majority sets two conditions for the passage of a bill: (a) more than 55% of member states vote “yes”; *and* (b) the population of the countries who have voted “yes” represents at least 65% of the total population of the EU.

For a limited number of issues, unanimity has been kept. Moreover, in the CT a sort of safeguard clause has been introduced. For simplicity we focus here on double majority.

<sup>18</sup>The presence of Portugal in the group of countries that occupy favorable positions should not sound too surprising if one considers that Portugal has succeeded in entering the Eurozone, getting large portions of cohesion funds, and taking over the current presidency of the Commission.

supported by Belgium and the Netherlands is confirmed by the spatial approach. Little power rests upon the Northern countries. Denmark, is never pivotal in any ideologically consistent coalition, whereas Finland and UK lose a lot of power from being “too skeptical” and “too close” each other. Also Greece and Italy lose power probably for the opposite reason of being “too enthusiastic.”

In particular, for a given player, being close to another player can alternatively have two different consequences: (a) sharing the power with that player that comes from occupying a certain portion of the space; (b) transferring a substantial part of her own power to the other player, who often succeeds in being pivotal just before her or *vice versa*.

Country	Votes	S-S	NBI	O-S Spatial
Germany	10	0.117	0.112	0.142
Portugal	5	0.055	0.059	0.141
Spain	8	0.095	0.092	0.118
France	10	0.117	0.112	0.114
Austria	4	0.045	0.048	0.092
Belgium	5	0.055	0.059	0.083
Netherlands	5	0.055	0.059	0.076
Ireland	3	0.035	0.036	0.059
UK	10	0.117	0.112	0.048
Sweden	4	0.045	0.048	0.047
Greece	5	0.055	0.059	0.045
Italy	10	0.117	0.112	0.025
Finland	3	0.035	0.036	0.009
Luxembourg	2	0.021	0.023	0.003
Denmark	3	0.035	0.036	0.000

Table 1: Power Values for Pre-Nice EU 15.

**Post-Nice – 27 Members** The enlargement is taking place under the rules of Nice. Table 2 shows the big changes in the distribution of power after the full enlargement to 27 members. Again the standard indices are linearly correlated to the votes: 69% of the power measured by the Shapley-Shubik index will be allocated to the current 15 members, whereas the six founding states will count for 31% of the power. However, once we shift to the spatial approach, this broad idea of change becomes much more radical. Many

Country	Votes	S-S	NBI	O-S Spatial
Czech Rep	12	0.034	0.037	0.132
France	29	0.087	0.078	0.101
Germany	29	0.087	0.078	0.091
Spain	27	0.080	0.074	0.089
Greece	12	0.034	0.037	0.063
Bulgaria	10	0.028	0.031	0.062
Netherlands	13	0.037	0.040	0.054
Lithuania	7	0.020	0.022	0.048
Italy	29	0.087	0.078	0.048
Poland	27	0.080	0.074	0.035
Belgium	12	0.034	0.037	0.033
Romania	14	0.040	0.043	0.030
Portugal	12	0.034	0.037	0.024
Slovakia	7	0.020	0.022	0.024
Hungary	12	0.034	0.037	0.023
Ireland	7	0.020	0.022	0.021
Latvia	4	0.011	0.013	0.021
Denmark	7	0.020	0.022	0.020
Sweden	10	0.028	0.031	0.017
UK	29	0.087	0.078	0.016
Cyprus	4	0.011	0.013	0.014
Austria	10	0.028	0.031	0.011
Finland	7	0.020	0.022	0.010
Slovenia	4	0.011	0.013	0.006
Luxembourg	4	0.011	0.013	0.004
Malta	3	0.008	0.009	0.003
Estonia	4	0.011	0.013	0.000

Table 2: Power Values for Post-Nice EU 27.

countries will lose a lot of their power as a consequence of their “unlucky positions” in the political space (see figure 6) and the unexpected result is possibly the fact that these “losers” are more frequently current members of the EU. UK’s spatial power decreases by more than 80% with respect to S-S index. Italy succeeds in being pivotal only in 4.8% of the ideologically consistent coalitions. Austrian power falls by 61%. In general those countries with extreme preferences tend to lose in the political game: saying “yes” too early or too late is not a good idea when a 72% qualified majority has to form.

The Franco-German axis is weaker: by requiring a higher qualified majority, Nice system subtracts the two big “moderate” countries a portion of the usual power. Some of the traditional allies, such as Belgium and Luxem-

bourg, are less powerful. In the future, the axis will probably need a higher support from Spain, which emerges from Nice as a very strong player, due to a very good position in the political arena.

Differently from the old members, the majority of new entrants could profit from favorable positions in the ideological space. The twelve newcomers collect a total 39.8% of the spatial power, despite the 30.8% quota of standard S-S power and 31.3% of the votes. Too much enthusiasm penalizes Poland. Moreover, accessing countries are very close to each other in the political area and Czech Republic is in a very good position at the center of this Eastern-bloc. Thus we could predict an unexpected prominent role for Czechs, whose 12 votes are enough to swing a large number of coalitions.

**Constitutional Treaty** The double majority system included in the new Constitution is favorable to the four most populous countries, in terms of standard S-S and NBI power. Note from table 3 that S-S and NBI are substantially different: S-S is much more concentrated in the hands of the largest six countries.<sup>19</sup> This is due to a technical difference between S-S and NBI that becomes relevant in the case of double majority.<sup>20</sup> A certain degree of caution is then necessary when choosing one or the other index. For example, in the debate on the winners and losers under CT the common perception has been that not only the four largest countries, but also the smallest six would have gained from double majority with respect to Nice (Baldwin and Widgrén, 2004). Actually, this is true only if NBI evaluations are used. S-S suggests that only the four largest members win, and all the others lose.

O-S power is more concentrated than the standard symmetric indices.

---

<sup>19</sup>In Table 3, the S-S and NBI values were calculated via the Monte Carlo method due to the large computational requirements needed to solve them analytically.

<sup>20</sup>As stated in section 2, both S-S and NBI are symmetric indices. Differences between them can arise from different values in the probabilities of the swung coalitions.

CT prescribes that at least 15 members must be in the winning coalition. Intuitively, the smallest countries tend to be pivotal thanks to this provision. Thus they are more likely to swing coalitions that are “already” composed by 14 members. For such coalitions the NIB is larger than S-S Value. Thus, small countries’ power under CT tend to be emphasized by NBI evaluations.

On the contrary, larger countries also swing coalitions that are composed by a larger number of players and do not reach the population threshold. The probability assigned to such coalitions by S-S can be much larger than the one assigned by NBI. This explains why the S-S index of largest countries is much higher.

Country	Votes	S-S	NBI	O-S Spatial
Germany	82,193	0.163	0.119	0.194
Spain	39,490	0.073	0.061	0.174
France	59,521	0.110	0.087	0.119
Bulgaria	8,170	0.020	0.025	0.063
Italy	57,844	0.107	0.085	0.045
Netherlands	15,983	0.033	0.035	0.042
Hungary	10,024	0.022	0.027	0.040
Poland	38,649	0.070	0.060	0.039
Lithuania	3,696	0.012	0.020	0.037
Sweden	8,883	0.020	0.026	0.027
UK	59,832	0.111	0.088	0.027
Greece	10,565	0.023	0.029	0.027
Malta	390	0.007	0.016	0.024
Austria	8,121	0.020	0.025	0.023
Romania	22,443	0.042	0.043	0.020
Ireland	3,820	0.012	0.020	0.016
Finland	5,181	0.015	0.022	0.015
Slovakia	5,401	0.015	0.022	0.013
Belgium	10,262	0.022	0.027	0.013
Cyprus	671	0.007	0.016	0.012
Denmark	5,349	0.015	0.022	0.009
Czech	10,272	0.023	0.027	0.008
Portugal	10,023	0.023	0.028	0.006
Slovenia	1,989	0.010	0.018	0.004
Latvia	2,417	0.010	0.018	0.001
Estonia	1,436	0.009	0.017	0.001
Luxembourg	441	0.007	0.016	0.000

Table 3: Power Values for the new Consitutional Treaty EU 27.

Moreover the concentration of the spatial power is higher under CT than under Nice. Germany emerges by far as the strongest member country. The Franco-German axis is very powerful: 31.3% of the winning coalitions are swung by one of the two countries. Actually, the CT voting system turns in favor of moderate/slightly enthusiastic voters. Spain is the second big player in the Council. During the intergovernmental negotiations, Spain fought very hard for an increase of the population threshold, aiming at getting a strong blocking power. Not only does the O-S method capture the increased blocking ability, but it also reflects the fact that a 65% majority favors the moderate enthusiasm of Spain, which succeeds more often in casting the “65<sup>th</sup>” vote after the “64” votes of more enthusiast members. With that

threshold, too much enthusiasm can work against a country, such as Italy, that, despite its population, loses almost two-thirds of its standard S-S power. The same rationale explains the loss by Poland or the Czech Republic. The new system is unfavorable to extremely skeptical countries: UK and Denmark lose most relative to their standard S-S power. However, except for Denmark, the new Constitution is less penalizing to big Euroskeptics, compared to Nice.

The Eastern bloc is less powerful than under Nice. The double majority empathizes the role of population in power apportionment, while the newcomers are small or middle-sized members. The ten Eastern countries represent 22% of the EU population and collect 22.6% of spatial power. For them, in aggregate, the political locations turn to be unfavorable (-0.7% with respect to the standard S-S power). CT prevents huge shifts of power toward Eastern Europe that otherwise occur with Nice. The double majority distributes the power more uniformly among the newcomers. The Czech Republic loses its leadership.

Spatial values also explain why among the middle sized countries the feelings toward CT have been mixed. Despite that for all of them NBI and S-S indices fall between 25-30%, some of them, such as Netherlands or Austria, gain in ideological values compared to Nice.

Spain and Poland's strong reluctance toward the CT proposal is inspired by losses both in terms of standard S-S and of spatial power: Nice favors Spanish and Polish pro-EU stance. The initial proposal of a 60% population threshold would have produced a significant loss for the two countries. The agreement for the Constitution has been reached thanks to a raising by 5 points in the two thresholds. If evaluated in terms of standard symmetric power, this adjustment does not explain why Spain and Poland have accepted to sign the Constitution, since both their S-S and NBI values are lower under CT than Nice. The spatial power explains much more: the raising of the thresholds allows Spain to be the second most powerful country in Europe and also improves the Polish position.

The new Constitution restricts the areas (such as taxation, welfare, foreign policy, budget, justice) in which the unanimity of member countries is required. UK, Denmark or Finland, for example, are reluctant to abandon unanimity in those areas. The spatial power approach provides arguments for explaining those countries' positions. In fact, if policy positions were disregarded, unanimity would imply equal power distribution. Thus we would not be able to understand the strong opposition to a qualified majority by selected countries. Once we adopt the spatial approach, we see that under

unanimity the power shifts in favor of either Euroskeptics or Euroenthusiasts. In particular, unanimity allows countries that are against centralization in sensitive policy domains to keep the highest amount of power. In the discussions regarding taxation and EU budget, for example, UK has always played a crucial role.<sup>21</sup>

## 4 The agenda setter and power

In section 2.4 we have argued that if there is an agenda setter, its most preferred bills should be more likely than others, putting the pivots for more likely bills in better positions. Within the EU legislative system the Commission has the monopoly of the proposals for a large portion of issues, playing the role of agenda setter. This can result in a substantial distortion of the power distribution within the Council.<sup>22</sup>

In the two-dimensional perspective developed in section 2.1.1:  $\Psi = H_1$ , the ordering generating function is  $f_i(\theta) = \langle \theta, P_i \rangle$ , and the issue  $U$  is defined by  $\theta \in [0, 2\pi)$ . So far, in our application to the EU Council we have adopted also the Owen-Shapley’s hypothesis of equal relevance of policy issues. In this section we remove this hypothesis, and we introduce examples of non-uniform probability distribution over the set  $[0, 2\pi)$ , and estimate the impact on power distribution.

Since hereafter the issues can have different probabilities, we are interested in “where” each country is pivotal: i.e., in which portions of the policy issue space. In figures 7 to 9 for Spring 2003 data and the three scenarios, respectively, we have represented the sectors in the  $H_1$  circle in which each country is pivotal. As soon as  $\theta$  rotates from 0 to  $2\pi$ , the pivotal role shifts from one country to another one, accordingly.

For example, in the pre-Nice context (see figure 7) if the Commission proposed a bill whose political contents are

---

<sup>21</sup>Here we do not include spatial power evaluations for a unanimity game in the EU. A table is available upon request. Also evaluations for the double threshold initially proposed by the Convention are available.

<sup>22</sup>The agenda setting power of the Commission must not be overestimated: the EU Treaty obliges the Commission to propose legislation when prompted by the Council or by the Parliament. The Council can amend the proposal by unanimity under the consultation procedure and by qualified majority (simple majority for the Parliament) under Codecision.



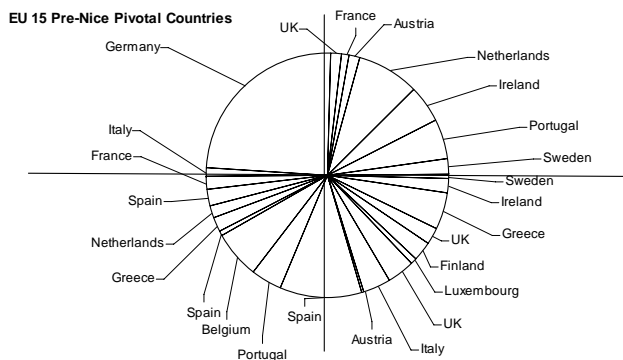

Figure 7: Pre-Nice EU15. Sectors in which countries are pivotal (Spring 2003).

- *pro-international and pro-intranational* ( $\hat{\theta} = \pi/4$ ), the most likely minimal winning coalition (ordered by level of enthusiasm) would be: {Greece, Italy, Spain, Belgium, Portugal, Germany, Luxembourg, Ireland, France, Netherlands}, and *Netherlands* is the pivotal country.
- *pro-intranational bill* ( $\hat{\theta} = \pi/2$ ), then a very likely outcome should be the winning coalition {Greece, Portugal, Italy, Spain, Luxembourg, Ireland, Austria, Belgium, UK, Germany}, with *Germany* as the pivotal country.

We know from section 2.4 that different expectations about the agenda setter's type will result in different probability distributions over the set of the issues. In other words, the probability distribution over the set  $[0, 2\pi)$  of all the possible bills can be anticipated by looking at the Commission's preferences.

We assume a simple linear probability density function

$$p(\theta) = \left\{ \begin{array}{ll} \left[ \frac{\theta + (\pi - \hat{\theta})}{\pi} \right] / \pi & \text{if } 0 \leq \theta < \hat{\theta} \\ \left[ \frac{1}{\pi} - \left( \frac{\theta - \hat{\theta}}{\pi} \right) \right] / \pi & \text{if } \hat{\theta} \leq \theta < \pi + \hat{\theta} \\ \left[ \frac{\theta - (\pi + \hat{\theta})}{\pi} \right] / \pi & \text{if } \pi + \hat{\theta} \leq \theta < 2\pi \end{array} \right\} \quad (10)$$

$\hat{\theta}$  is what the players expect as the most preferred issue by the Commission. Function (10) says that the probability density of a proposal  $\theta$  will

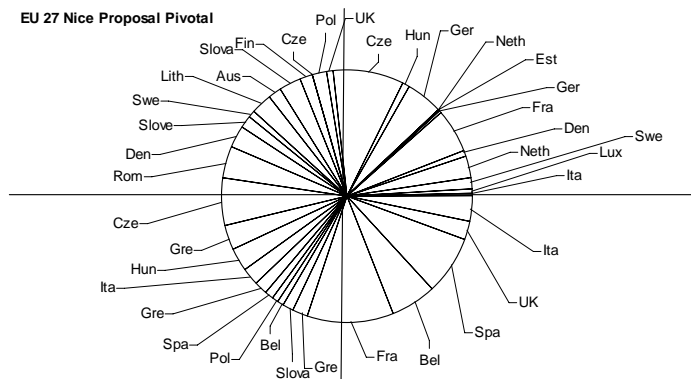

Figure 8: Post-Nice EU27. Sectors in which countries are pivotal (Spring 2003).

increase linearly as  $\theta$  approaches  $\hat{\theta}$ . Moreover the probability density falls to zero with regards to the opposing issue  $\hat{\theta} + \pi$ .

We further assume that the Commission prefers to promote integration with respect to the *status quo*. Thus the countries expect  $\hat{\theta}$  to lie in  $[0, \frac{\pi}{2}]$ . We further suppose that the following three distributions reflect alternative priors of the states about the Commission's decision making.

- For a purely *pro*-international modal issue:  $\hat{\theta} = 0$ ; we show the graph of this version of equation (10) in figure 10(a) below.
- Alternatively, if the Commission preferred issues that are *pro*-international *and* *pro*-intranational, we would expect a density function with mode in  $\hat{\theta} = \pi/4$ , whose graph is represented in figure 10(b).
- If the most preferred issue is purely *pro*-intranational, thus  $\hat{\theta} = \pi/2$  and the probability distribution will be as in 10(c).

Of course, these are just examples of our *ad hoc* probability distribution. Nonetheless they can capture alternative behavior and preferences of the agenda setter and get a reliable idea on how the power shifts from some players to others as a result of the action of the agenda setter. In more sophisticated cases we could have density functions with different or multiple modal values, or non-linear relations between issues and probability. In



plain why in the pre-Nice scenario (qualified majority close to 70%, table 4) Austria, UK, Finland and Sweden gain additional value with respect to the Owen-Shapley spatial value. For the same reason (saying “yes” too early)

Country	$\hat{\theta} = \mathbf{0}$	$\hat{\theta} = \pi/4$	$\hat{\theta} = \pi/2$
Austria	0.136	0.129	0.091
Belgium	0.048	0.035	0.074
Denmark	0.000	0.000	0.000
Finland	0.014	0.010	0.005
France	0.052	0.106	0.162
Germany	0.089	0.145	0.195
Greece	0.055	0.040	0.035
Ireland	0.085	0.069	0.043
Italy	0.019	0.016	0.015
Luxembourg	0.005	0.003	0.002
Netherlands	0.075	0.104	0.106
Portugal	0.192	0.154	0.118
Spain	0.096	0.064	0.043
Sweden	0.074	0.068	0.058
UK	0.061	0.058	0.055

Table 4: Probabilistic Spatial Values with Different Types of Agenda Setter (pre-Nice EU 15)

Italy, Belgium and Greece lose a quota of their power. In general, the expectations of a distorted pro-EU agenda setter, as depicted by (10), can result in 9.8% redistribution of the total O-S power.<sup>24</sup>

**Post-Nice 27 Members** The EU 27 scenario resulting from Nice voting rules is more complex. We have already remarked that the accession of many Euroenthusiasts will shift the “center” of the political space toward Euroenthusiasm, making the current members relatively more Euroskeptic. Thus, the countries who gain from pro-EU proposals are more frequently current members (Germany, Ireland, UK, Austria, Finland, Italy). This mitigates the risk of large concentration of O-S power on the so-called Eastern bloc.

---

<sup>24</sup>Intuitively, the amount of power redistribution is negatively related to the variance of the probability distribution of the issues: when the agenda setters’ proposals are easy to predict, the probability of playing a pivotal role is concentrated.

Country	$\hat{\theta} = 0$	$\hat{\theta} = \pi/4$	$\hat{\theta} = \pi/2$
Austria	0.007	0.015	0.023
Belgium	0.020	0.012	0.015
Bulgaria	0.053	0.065	0.083
Cyprus	0.007	0.013	0.019
Czech	0.029	0.034	0.046
Denmark	0.005	0.019	0.034
Estonia	0.016	0.028	0.041
Finland	0.017	0.018	0.019
France	0.097	0.069	0.047
Germany	0.277	0.279	0.214
Greece	0.012	0.012	0.017
Hungary	0.006	0.008	0.008
Ireland	0.023	0.046	0.070
Italy	0.086	0.068	0.062
Latvia	0.016	0.021	0.029
Lithuania	0.029	0.035	0.048
Luxembourg	0.000	0.000	0.000
Malta	0.000	0.002	0.003
Netherlands	0.041	0.035	0.021
Poland	0.001	0.002	0.002
Portugal	0.069	0.063	0.044
Romania	0.051	0.037	0.023
Slovakia	0.022	0.014	0.012
Slovenia	0.007	0.012	0.016
Spain	0.037	0.035	0.055
Sweden	0.002	0.005	0.008
UK	0.069	0.056	0.043

Table 5: Probabilistic Spatial Values with Different Types of Agenda Setter (Post-Nice EU 27)

Due to the large number of members and to the relatively high majority threshold agreed at Nice (around 72%) the pivotal role can rapidly pass from one country to another one as the proposal changes. This makes more than 34% of the allocation of spatial power to depend upon the agenda setter's preferences, as given by (10). This confirms what we could intuitively expect: raising the majority threshold reduces the chance to form winning coalitions, causing the identity of the pivot to be highly responsive to the Commission's proposal. The results are presented in table 5.

**Constitutional Treaty** The CT reduces the qualified majority to 65%, provided at least 15 members have voted “yes.” This lowering has at least two effects: it makes the pivotal role of moderate countries more likely; it reduces the sensitivity of power distribution to the agenda setter’s preferences. When the Commission turns from indifference to pro-EU attitude “only” 16.9% of total O-S power is reallocated.

Country	$\hat{\theta} = 0$	$\hat{\theta} = \pi/4$	$\hat{\theta} = \pi/2$
Austria	0.029	0.027	0.030
Belgium	0.025	0.005	0.003
Bulgaria	0.062	0.071	0.079
Cyprus	0.016	0.018	0.021
Czech	0.010	0.011	0.013
Denmark	0.012	0.013	0.015
Estonia	0.001	0.001	0.001
Finland	0.019	0.021	0.025
France	0.099	0.092	0.082
Germany	0.280	0.249	0.165
Greece	0.027	0.030	0.036
Hungary	0.059	0.068	0.077
Ireland	0.018	0.021	0.024
Italy	0.035	0.023	0.026
Latvia	0.001	0.002	0.002
Lithuania	0.052	0.059	0.069
Luxembourg	0.000	0.000	0.000
Malta	0.023	0.026	0.031
Netherlands	0.013	0.015	0.017
Poland	0.034	0.038	0.043
Portugal	0.006	0.006	0.008
Romania	0.017	0.020	0.023
Slovakia	0.017	0.019	0.021
Slovenia	0.006	0.007	0.008
Spain	0.099	0.113	0.131
Sweden	0.017	0.016	0.019
UK	0.025	0.027	0.031

Table 6: Probabilistic Spatial Values with Different Types of Agenda Setter (Constitutional Treaty EU 27)

Still Germany, Spain and France are very powerful, however Bulgaria and Hungary are reinforced. The distortion produced by the agenda setter results more frequently in favor of middle sized Eastern countries.

## 5 Conclusion

This paper has presented power indices based on the preferences of the players and the agenda setter in a coalition form game. We have applied this index to the case of the European Union, which is facing a large expansion.

Measuring power using simple Shapley-Shubik and Banzhaf indices do not capture how political preferences affect power. In short, when looking at possible coalition formation, countries who are relatively “pro” a particular issue will be more likely to vote “yes” *before* those countries who are “con”. Majorities formed by *pro*-countries are more likely than majorities formed by *con*-countries. Being able to swing a large number of coalitions puts the voter in a powerful position *only if those coalitions are also likely to occur*. More likely coalitions are those ones that include similarly minded voters. Thus the power of countries will be determined not only by the number of votes they have and the number of votes needed for a majority, but also by the attitudes that the countries hold. In cases where unanimity is needed, for example, the most “con” countries hold the most sway. In games, where a two-thirds majority is needed countries who are moderately “con” then become more powerful since the likelihood of them joining the coalition “too early” is small.

The attitudes that create political coalitions depend also on the content of the issue to vote on. If the issue is proposed by an agenda setter, the agenda setter’s preferences can distort the likelihood of the coalitions and ultimately the distribution of power.

Using principal component analysis we are able to extract countries’ attitudes toward the EU. These attitudes are then used to create what we call the *spatial Owen-Shapley index*. Our results show, for example, that countries with the greatest number of votes (and hence highest simple Shapley-Shubik indices) do not necessarily have the greatest power after considering their preferences.

The spatial approach captures the current leadership of the Franco-German axis and the political weakness of Northern Euroskeptics and Mediterranean Euroenthusiasts. After enlargement the “positions” in the political space will become even more relevant as a source of power, and, if the Nice rules are not changed, the Western members will frequently occupy unfavorable positions. The closeness of the new members will result in a strong Eastern political bloc.

The double majority included in the CT restores concentration of power

in favor of big and politically moderate members; the Eastern bloc is less powerful. Lowering the majority threshold causes those countries with extreme preferences to suffer more.

In our spatial political games we have modeled the agenda setter's preferences through an ad hoc distribution which assigns higher probability to pro-European issues. We find that with higher majority thresholds the EU Commission's preferences can have a larger impact on the power distribution, i.e., a greater share of power can change hands. Under Nice the risk of distortions of the European political game caused by the Commission's proposals is high. This risk grows when the number of members increases and when there is little uncertainty about the Commission's preferences. Within the debate on the institutional reforms of the EU, our findings show the need for a serious reflection about the strong concentration of the legislative prerogatives within the Council and about the recognition of a greater political role to the Commission.

In summary, the measurement of power based on preferences leads to interesting and sometimes unexpected results, which can be used as a measure of the prospect of participating in political games. Nonetheless, a certain degree of caution is necessary. First, power index analysis, even of the spatial kind, is reasonable only from a constitutional viewpoint, when the policy issues to vote on are unknown and the random future contingencies tend to offset each other in a "large number" perspective. Second, for low dimensional policy spaces, the spatial power indices seem to be quite responsive to slight differences in preference measurement. Third, the assumption of exogeneity of preferences can be challenged if, for example, the voters can strategically commit to political positions aiming at maximizing their power. Finally, since we use the preferences of the citizens to evaluate the political location of their elected representatives, a principal-agent problem could arise. For future work, we envisage the possibility of extending our model with non-cooperative stages which take these aspects into account, as well as a more sophisticated role for the agenda setter.



## 6 Appendix A: Eurobarometer survey questions

The Eurobarometer survey covers the population of the EU member states. The basic sample design consists of a number of sampling points that are proportional to the population size and density. In each country almost 1,000 face-to-face interviews are carried out. We use three Eurobarometer surveys (Fall 2001, Fall 2002 and Spring 2003). The part of the interview which is relevant for our analysis is the one which concerns the opinions of the people whether to centralize some policy domains, which is based on the following question: “For each of the following area, do you think that decisions should be made by the (NATIONALITY) government, or made jointly within the European Union?” (EC 2003)<sup>25</sup>

## 7 Appendix B: Data analysis

### 7.1 Principal components

Factor models have been used in economic analysis and forecasting to reduce the dimensionality of large data sets. We apply the standard techniques of factor analysis/principal components using Stata 8.0. In our analysis we have 25 variables,  $x_i$ ,  $i = 1, \dots, p (= 25)$ , with a considerable degree of (positive) correlation among these variables. This leads to the use of factor analysis to capture underlying, latent variables that can account for this high degree of correlation among these variables. The aim of factor analysis is to account for the covariances of the observed variables in terms of a much smaller number of hypothetical variables,  $f_r$ ,  $r = 1, \dots, k$ ;  $k \ll 25$ , such that the partial correlation coefficients between the original variables after eliminating the effect of  $f_r$ 's are close zero. Each variable,  $x_i$  is modeled as a linear function of  $k$  common “factors” or latent variables:

$$x_i = \sum_{r=1}^k \lambda_{ir} f_r + \mu_i, i = 1, \dots, p, \quad (11)$$

where  $f_r \in \mathbf{f}$  is the  $r^{th}$  common factor,  $k$  is the number of factors being specified,  $\mu_i$  is a residual source of variation affecting only  $x_i$ , and the coefficients

---

<sup>25</sup>We excluded the Terrorism variable since we did not have a response for this variable for all 27 countries.

Issues	
1	Defense
2	Protection of the environment
3	Currency
4	Humanitarian aid
5	Health and social welfare
6	Basic rules for broadcasting and press
7	Fight against poverty/social exclusion
8	The Fight Against Unemployment
9	Agriculture and fishing policy
10	The support of regions which are experiencing economic difficulties
11	Education
12	Scientific and technological research
13	Information about the EU, its policies and institutions and bodies
14	Foreign policy towards countries outside the EU
15	Cultural policy
16	Immigration policy
17	Rules for political asylum
18	The fight against organized crime
19	Police
20	Justice
21	Accepting refugees
22	Juvenile crime prevention
23	Urban crime prevention
24	The fight against drugs
25	The fight against the trade in, and exploitation of, human beings
26	The fight against international terrorism

Table 7: Eurobarometer survey questions.

$\lambda_{ir} \in \Lambda$  are called the *factor loadings* of  $x_i$  on  $f_r$ .

The method of principal components minimizes

$$V(k) = \min_{\Lambda, \mathbf{f}} \left( \sum_{i=1}^p \left[ x_i - \sum_{r=1}^k \lambda_{ir} f_r \right] \right)^2, i = 1, \dots, p$$

The estimated factors,  $\hat{f}_r$ , are the eigenvectors corresponding to the  $k$  largest eigenvalues of the matrix  $\mathbf{xx}'$ , and  $\hat{\Lambda} = (\hat{\mathbf{ff}}') \mathbf{xf}'$  are the corresponding factor loadings. If we denote  $\delta_r$ ,  $r = 1, \dots, k$  the eigenvalue for the  $r^{th}$  factor, then each factor explains  $\delta_r/p$  proportion of the total variance in the data set (since  $\sum_{r=1}^p \delta_r = p$ ). We have chosen  $k = 2$  in order to measure power

values for each country in two dimensions; however, the two factors explain over 70% of the variance in the data sets.

Furthermore in cases where  $k > 1$ , there are an infinite number of choices for  $\mathbf{\Lambda}$ . Thus to elicit clearer patterns in the data, we use the varimax rotation procedure, whereby we “rotate” the factors in such a way that the new loadings tend to be either relatively large or small in absolute size compared with the original ones. Since each factor is a vector of correlation coefficients, the most interpretable factor is one based upon correlation coefficients which are either close to one in absolute value or close to zero in absolute value (Lawley and Maxwell, 1971).

We can then inspect the rotated factor loadings to see which of the original variables are most highly correlated with each of the factors. Inspection of the loadings shows that, in general, that the first factor is most highly correlated with international issues, while the second factor is associated with domestic/internal issues. Next the factors are then “scored”, which assigns weights for the contribution of each variable to the factor. The mean of each the scored factor is zero and the standard deviation is 1. Each scored factor for each country is plotted in figures 5 and 6 above (Lawley and Maxwell, 1971).

## 7.2 PCAs Spring 2003

Given our data set, principal component analysis gives the following tables, where table 8 reports the results for EU 15 for Spring 2003, and table 9 reports results for EU 27, Spring 2003. Each value for each variable is a correlation coefficient that measures by how much the variable is correlated with the respective factor. Looking at which variables are more highly correlated with each factor allows us to give an interpretation to each factor (i.e., the intra-national and inter-national factors).

## 8 Appendix C: Owen-Shapley spatial value calculation

This section gives more description of how we calculate the Owen-Shapley spatial value. For a given year, first we calculate the scored factors for EU 15 and EU 27, as described above. The scored factors are plotted in figure

Variable	Factor 1	Factor 2
defence	0.67	0.41
environment	0.82	0.36
currency	0.56	0.38
humanitarian aid	0.72	0.44
health and social welfare	0.28	0.89
media	0.08	0.64
poverty and social exclusion	0.47	0.61
unemployment	0.40	0.74
agriculture	0.83	0.14
regional aid	0.13	0.32
education	0.38	0.80
research	0.61	0.65
information	0.71	0.25
foreign policy	0.73	0.47
cultural policy	0.28	0.69
immigration	0.77	0.59
political asylum	0.74	0.60
organized crime	0.76	-0.02
police	0.41	0.85
justice	0.47	0.81
accepting refugees	0.74	0.54
juvenile crime	0.10	0.91
urbancrime	-0.15	0.84
drugs	0.72	0.26
exploitation of human beings	0.94	-0.03

Table 8: Rotated factors for EU 15 (Spring 2003).

5 and 6. For each country, we then calculate its relative “pro-con” value for 10,000 points from zero to  $2\pi$  using the formula:

$$y_i = f_{1i} \cos \theta + f_{2i} \sin \theta, \theta \in [0, 2\pi], i = 1, \dots, n$$

where  $y_i$  is a country  $i$ 's relative sentiment (ranking) on issue  $\theta$ , and  $n$  is the number of countries (either 15 or 27) and  $f_{1i}$  and  $f_{2i}$  are the two factors for each country. We use 10,000 values of  $\theta$  in the  $[0, 2\pi]$  range in order to get many rankings, which will insure us that we catch all of the “switching points,” i.e., the points along  $[0, 2\pi]$  where the relative rankings of countries' preferences change.

For each  $\theta$ , we rank  $y_i$ ,  $i = 1, \dots, n$ , from highest to lowest (i.e., most pro to most con), and record at what values of  $\theta$  the rankings change. Then we calculate the pivotal voters—given the particular rules of the game—and

Variable	Factor 1	Factor 2
defence	0.45	0.65
environment	0.54	0.61
currency	0.66	0.23
humanitarian aid	0.66	0.55
health and social welfare	0.34	0.88
media	0.62	0.34
poverty and social exclusion	0.33	0.87
unemployment	0.22	0.94
agriculture	0.49	0.65
regional aid	0.07	0.80
education	0.22	0.90
research	0.48	0.76
information	0.46	0.70
foreign policy	0.86	0.23
cultural policy	0.82	0.09
immigration	0.83	0.43
political asylum	0.88	0.32
organized crime	0.24	0.79
police	0.42	0.83
justice	0.47	0.79
accepting refugees	0.90	0.28
juvenile crime	0.33	0.83
urbancrime	0.23	0.73
drugs	0.16	0.91
exploitation of human beings	0.30	0.74

Table 9: Rotated factors EU 27 (Spring 2003).

record the interval length for which each country is pivotal. To calculate the Owen-Shapley spatial value we add the length of the pivotal intervals for each country. Lastly we normalize the results so the sum of power values is equal 1.

To calculate the power-values using a non-uniform distribution, we first take the length of the intervals along  $[0, 2\pi]$  for which each country is pivotal. For each interval we take the integral using equation (10). We then sum the integrals for each country and normalize them to get the power values.

We repeat each of the steps for the three years and take average of the Owen-Shapley spatial values. The calculations were done in Mathematica 3.0. The code is available upon request.

## References

- [1] Alesina, A. F. I. Angeloni and L. Schuknecht (2002), “What Does the European Union Do?”, CEPR Discussion Paper no. 3115, London.
- [2] Alesina, A. and R. Perotti (2004), “The European Union: A Politically Incorrect View”, *Journal of Economic Perspectives*, Vol. 18, No. 4, pp. 27-48.
- [3] Baldwin, R. E. Berglof, F. Giavazzi and M. Widgrén (2001), *Nice Try: Should the Treaty of Nice Be Ratified?* CEPR, London.
- [4] Baldwin, R. E. and M. Widgrén, (2004), *Winners and losers under various dual majority rules for the EU’s Council of Ministers*, (mimeo).
- [5] Banzhaf, John F. III (1965), “Weighted Voting doesn’t Work: A Mathematical Analysis”, *Rutgers Law Review*, 19, pp. 317-343.
- [6] Benoit, J.P. and L.A. Kornhauser (2002), “Game-Theoretic Analysis of legal Rules and Institutions”, *Handbook of Game Theory*, vol. 3, R.J. Auman and S. Hart, editors, Elsevier Science B. V., pp. 2231-2269.
- [7] Berglof, E., B. Eichengreen, G. Roland, G. Tabellini and C. Wyplosz (2003), *Built to Last: a Political Architecture for Europe*, CEPR series, Monitoring European Integration, No. 12, London.
- [8] Brams S.J. and P.C. Fishburn (2002), “Voting Procedures”, *Handbook of Social Choice and Welfare*, vol. 1, K.J. Arrow, A.K. Sen and K. Suzumura, editors, Elsevier Science B. V., pp. 173-236.
- [9] Coleman, J.S. (1971), “Control of Collectivities and the Power of a Collectivity to Act”, in *Social Choice*, B. Lieberman, editor, Gordon and Breach, London, pp. 269-300.
- [10] European Commission (2003), [http://europa.eu.int/comm/public\\_opinion](http://europa.eu.int/comm/public_opinion), March, B66-B68.
- [11] Felsenthal, D.S. and Machover, M. (1998), *The Measurement of Voting Power*, Edward Elgar Publ., Oxford.
- [12] Felsenthal, D. S. and M. Machover (2001), “The Treaty of Nice and Qualified Majority Voting”, *Social Choice and Welfare*, 18, pp. 431-464.

- [13] Grofman, B., G. Owen, N. Noviello and A. Glazer (1987), “Stability and Centrality of Legislative Choice in the Spatial Context”, *American Political Science Review*, 81, pp. 539-553.
- [14] Holler M. J. and G. Owen, editors (2001), *Power Indices and Coalition Formation*, Kluwer Academic Publisher, Boston.
- [15] Lawley, D. N. and Maxwell, A. E. (1971), *Factor Analysis as a Statistical Method*, American Elsevier Publishing, New York.
- [16] McKelvey (1976), “Intransitivities in Multidimensional Voting Models and some Implications for Agenda Control”, *Journal of economic Theory*, 12, pp. 472-482.
- [17] McLean, R.P. (2002), “Values of Non-Transferable Utility Games” in *Handbook of Game Theory*, vol. 3, R. J. Aumann and S. Hart, editors, Elsevier Science B. V., pp. 2077-2120.
- [18] Monderer, D. and Samet, D. (2002), “Variations on the Shapley Value” in *Handbook of Game Theory*, vol. 3, R. J. Aumann and S. Hart, editors, Elsevier Science B. V., pp. 2055-2076.
- [19] Mueller, D. C. (2003), *Public Choice III*, Cambridge University Press, Cambridge.
- [20] Napel, S. and M. Widgrén (2004), “The Inter-Institutional Distribution of Power in EU Codecision”, CESifo Working Paper No. 1347, Munich, forthcoming in: *Social Choice and Welfare*.
- [21] Noury, A. and G. Roland (2002), “More Power to the European Parliament?”, *Economic Policy*, 35, pp. 281-319.
- [22] Ordeshook, P.C. (1997), “The Spatial Analysis of Elections and Committees: Four Decades of Research”, in *Perspectives on Public Choice*, D.C. Mueller, editor, Cambridge University Press, Cambridge, UK, pp. 247-270.
- [23] Owen, G. (1972), “Political Games”, *Naval Research Logistics Quarterly*, 18, pp. 345-354.
- [24] Owen, G. (1975), “Evaluation of a Presidential Election Game”, *American Political Science Review*, 69, pp. 947-953.

- [25] Owen, G. (1995), *Game Theory*, Academic Press, San Diego.
- [26] Owen, G. and L. S. Shapley (1989), “Optimal Location of Candidates in Ideological Space”, *International Journal of Game Theory*, 18, pp. 339-356.
- [27] Persson, T. and G. Tabellini (2003), *The Economic Effects of Constitutions*, The MIT Press, Cambridge, MA.
- [28] Rabinowitz, G. and S. E. Macdonald (1986), “The Power of the States in U. S. Presidential Elections”, *American Political Science Review*, 80, pp. 65-87.
- [29] Rapoport, A. and E. Golan (1985), “Assessment of Political Power in the Israeli Knesset”, *American Political Science Review*, 79, pp. 673-692.
- [30] Romer, T. and H. Rosenthal, (1978), “Political Resource Allocation, Controlled Agendas, and the Status Quo”, *Public Choice*, 33, pp. 27-44.
- [31] Rosenthal, H. (1990), “The Setter Model”, in *Advances in the Spatial Theory of Voting*, J. M. Enelow and M. J. Hinich, editors, Cambridge University Press, Cambridge, pp. 199-232.
- [32] Persson, T. and G. Tabellini (200), *Political Economics, Explaining Economic Policy*, The MIT Press, Cambridge, MA.
- [33] Shapley, L. S. (1953), “A Value for  $n$ -Person Games” in *Contributions to the Theory of Games*, vol. II, H. W. Kuhn and A. W. Tucker, editors, Annals of Mathematics Studies, 28, Princeton University Press, Princeton, pp. 307-317.
- [34] Shapley, L. S. (1977), “A Comparison of Power Indices and a Nonsymmetric Generalization”, Paper P-5872, The Rand Corporation, Santa Monica.
- [35] Shapley, L. S. and M. Shubik (1954), “A Method for Evaluating the Distribution of Power in a Committee System”, *American Political Science Review*, 48, pp. 787-792.
- [36] Sloss, J. (1973), “Stable Outcomes in Majority Voting Games”, *Public Choice*, 15, pp. 19-48.



- [37] Snyder, J. M. Jr, M. Ting and S. Ansolabehere (2005), “Legislative Bargaining Under Weighted Voting”, *American Economic Review*, Vol. 95, No. 4.
- [38] Straffin, P. D. (1994), “Power and Stability in Politics”, *Handbook of Game Theory*, vol. 2, R. J. Aumann and S. Hart, editors, Elsevier Science B. V., pp. 1127-1151.
- [39] Von Neumann, J. and O. Morgenstern (1944), *Theory of Games and Economic Behavior*, Princeton University Press, Princeton, reprint of the third edition, 2004.
- [40] Weber, R. J. (1988), “Probabilistic Values for Games”, in *The Shapley Value: essays in honor of Lloyd S. Shapley*, A. E. Roth, editor, Cambridge University Press, Cambridge, pp. 101-119.
- [41] Widgrén, M. (1994), “Voting Power in the EC and the Consequences of Two Different Enlargements”, *European Economic Review*, 38, pp. 1153-1170.